

LOC		DIST		REVISIONS					
AF		50		P	LTR	DESCRIPTION	DATE	DWN	APVD
		R				REVISED PER ECR-13-001204	25JUN13	KH	PD

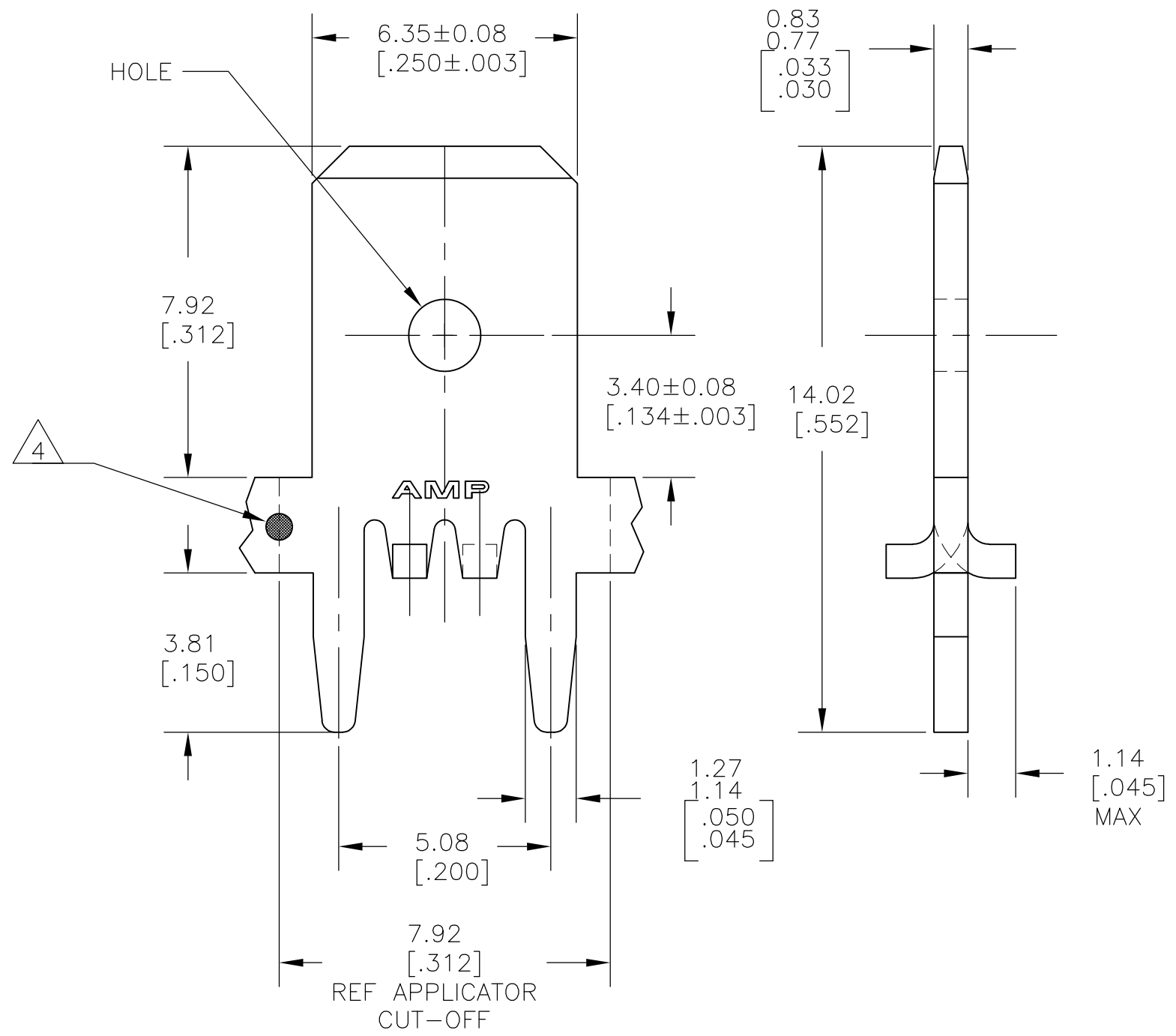

- 1 CONTINUOUS STRIP ON REELS.
- 2 TIN PLATE 0.00381 [.000150] MIN OVER 0.00254 [.000100] MIN THK COPPER OR TIN PLATE 0.00381 [.000150] MIN OVER 0.00127 [.000050] MIN THK NICKEL.
- 3 REELED WITH INTERLEAVING PAPER
- 4 OPTIONAL ID MARK, LOCATED APPROX AS SHOWN.
- 5 PRELIMINARY - NOT FOR PRODUCTION
- 6 PREPRODUCTION - FASR REQUIRED

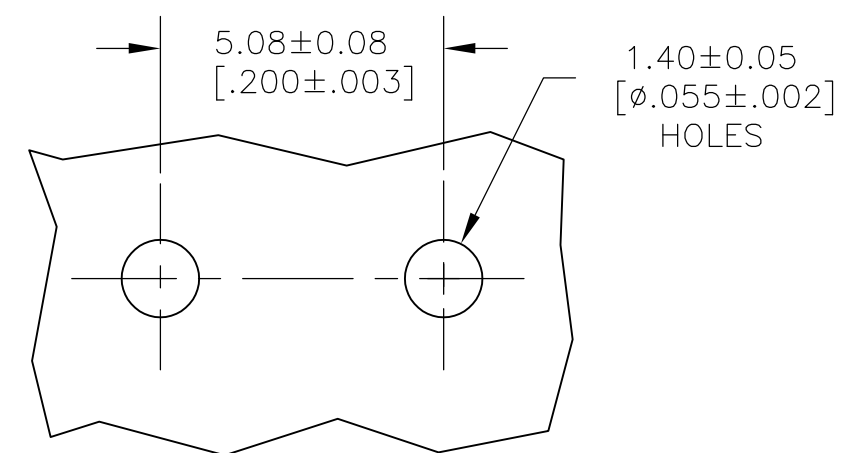

P.C. BOARD HOLE PATTERN

3 STANDARD	BRASS	6 63824-5
REVERSE	BRASS	63824-3
STANDARD	BRASS	5 63824-2
STANDARD	BRASS	63824-1
REELING	MATERIAL	PART NO.

THIS DRAWING IS A CONTROLLED DOCUMENT.		DWN	JR RUTH	20FEB01	STE TE Connectivity				
DIMENSIONS: mm [INCHES]		CHK	MS FEHER	20FEB01					
TOLERANCES UNLESS OTHERWISE SPECIFIED:		APVD	N DEIBERT	20FEB01	NAME TAB, FASTON, P.C.BOARD 6.35 [.250]				
0 PLC ± -		PRODUCT SPEC	-						
1 PLC ± -		APPLICATION SPEC	114-2115						
2 PLC ± 0.25 [.010]		WEIGHT	-						
3 PLC ± -		SIZE	A3	CAGE CODE	00779	DRAWING NO	C-63824	RESTRICTED TO	-
4 PLC ± -		MATERIAL		SEE TABLE		FINISH		2	
ANGLES ± -		CUSTOMER DRAWING		SCALE	8:1		SHEET	1 OF 1	
MATERIAL		REV		R		REV		R	